

installation instructions:

# GABLE VENT

## SAFETY INSTRUCTIONS

Make sure to use the correct tools recommended.

Wear safety goggles.

Follow fixture, power tools, and paint manufacturers' instructions and users manuals.

Use common sense and follow good construction practices.

## TOOL & MATERIAL CHECKLIST

- construction adhesive
- caulk
- caulking gun
- finishing nails
- hammer
- paint
- chalk line box & pencil

## IMPORTANT INFO

- It is highly recommended that you prime & paint/finish our gable vents with 100% acrylic latex paint before installation.
- Once installed, you can apply any necessary touchup paint/finish.
- Clean installation surface and back of vent of all dirt and dust with a clean cloth or sponge.
- Make sure that the surface and the back of the vent are completely dry before attempting installation.
- Measure and mark the location where the vent is going to be installed.

## INSTALL INSTRUCTIONS:

1. Lay the vent face down on a soft surface that will not scratch/dent the medallion detail.
2. Apply a 1/2" bead of adhesive caulk all the way around the back edge of the vent.
3. Gently press the vent up against the wall.
4. When pressing the vent up against the wall, some adhesive caulk will seep out. Smooth excess caulk around the vent with a finger or the putty knife and apply extra caulk that is needed to fill in any gaps.
5. Wipe off any excess adhesive caulk with a sponge or damp rag.
6. Noncorrosive fasteners can be used for additional support.
7. Fill any nail holes with caulk and smooth the surface with a finger or the putty knife. If any excess caulk is left, let it dry, and then lightly sand it down with extra fine sand paper.
8. Touch up the vent with any paint that is needed.

## EXAMPLE DIAGRAM:

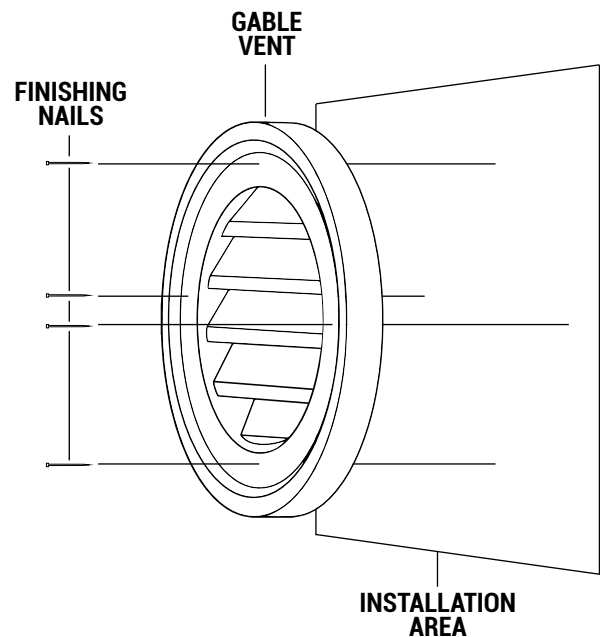

We Can Help. Call (866) 607-0453



**EKENA**  
MILLWORK

Industry leading manufacturer of urethane, PVC, wood, rustic, and metal millwork

[www.ekenamillwork.com](http://www.ekenamillwork.com)

staining guide:

# URETHANE FAUX WOOD

## Safety Instructions

### READ CAREFULLY BEFORE STAINING

To avoid inhaling any fumes when using stains, paints or topcoats, it is extremely important to use adequate ventilation. Keep all materials out of the reach of children. Close all containers after use. Please be sure to follow the stain manufacturer's safety procedures.

### MATERIAL CHECKLIST

- gloves
- quality brush(es) for stain
- quality brush for topcoat\*
- staining rags
- mineral spirits
- stain
- topcoat\*

### SPECIAL INSTRUCTIONS & NOTES

- **\*Topcoat is required for exterior applications**
- It is recommended to apply stain when temperatures are between 50 to 90 degrees F and relative humidity is below 80%.
- Apply stain to all exposed edges and ends of your stainable urethane product. **IMPORTANT:** Any urethane product that will be exposed to weather must be finished within 90 days of exposure.
- **DO NOT** apply stain or topcoat while dew is present.
- **DO NOT** apply stain in direct sunlight.
- **DO NOT** sand stainable polyurethane product.

### RECOMMENDATIONS:

Use water based stain or a quality gel stain. If using gel stain, it should be cut 2-1 with 2 parts stain and 1 part mineral spirits. Follow gel stain drying times found on the container. If product will be used in an exterior application, exterior water based stain should be used with a quality exterior top coat.

### STEP 1: SURFACE PREPARATION

Prior to staining, be sure to clean and prepare surfaces. Use a clean rag dampened with mineral spirits to wipe the entire surface, removing all contaminants.

**Tip: Compressed air can be used to blow dust off of deeply grooved products.**

### STEP 2: APPLY STAIN

Stir the stain well with a stir stick. Improperly mixed stain will not dry correctly. Apply the stain with brush, apply the stain directly on the surface of the polyurethane product. Ensure that you work the stain into the grain, fill all crack and crevices.

**Tip: If your product is 10' or greater, apply the stain in sections.**

### STEP 3: BLEND

After product has been fully stained, take a clean, dry short bristle brush and begin dry brushing and blending the stain in the direction of the grain. Every few strokes, remove the excess stain onto a clean rag or shop towel. Continue this process until you have completed the entire product or area of the product and it appears as any stained wood product. Pay special attention to any deep grooves and corners. Do not let stain collect or pool in these areas. For lighter shades, remove more of the stain when dry brushing. For darker applications, repeat Steps 2 and 3. **Make sure first application is dry before applying second coat of stain.**

**Tip: To reduce bristle loss during the blending process, periodically tug on the bristles with a rag or shop towel. This will help remove loose bristles so the strands do not fall off and stick to the product.**

### STEP 4: TEST FOR DRYNESS

To test for dryness, use a gloved hand to touch an area of the product that is hidden or near the edge. The stain is completely dry when nothing comes off on the glove. If it is not dry, test again every hour until dry.

### STEP 5: APPLY TOPCOAT (FOR EXTERIOR APPLICATIONS)

Stir the topcoat well with a stir stick. To apply the topcoat, wet the tips of the brush to apply a single, very thin layer of topcoat. Apply topcoat in a smooth and even motion. Do not use excessive brush strokes, as this may cause the topcoat to bubble or loosen the stain. If you find an area that is too light or dark with stain, apply a small amount of mineral spirits and wipe. Then reapply the stain and dry brush and blend area. After it is dry, apply topcoat again.

**Tip: To reduce bristle loss during the topcoat process, periodically tug on the bristles with a rag or shop towel. This will help remove loose bristles so the strands do not fall off and stick to the product.**

## Maintenance

---

All exterior finishes are affected by exposure to sun, weathering, moisture and air pollutants. Typical durability of the topcoat is 3-5 years, but could be less depending upon location conditions. When the topcoat feels rough, it's time to reapply a new layer of topcoat. DO NOT use topcoat that is more than 3 years old or that has not been stored in proper temperature conditions.

### AFTER STAINING

For fine scratches or nicks in stain:

1. Wipe the damaged surface with mineral spirits.
2. Apply the stain to the scratched area with a cotton swab or an artist brush.
3. Blend the stain until color match is achieved.
4. If clear topcoat is required, wait until the stain is dry before applying topcoat.
5. Apply a fine layer of topcoat over the repaired area with a clean cotton swab or small brush.

**Tip:** *Fine scratches can be touched up by daubing stain onto the area even if topcoat has already been applied.*

### CREATE A UNIQUE LOOK WITH MULTILAYER STAINS

You can create an artistic look by using two different color stains. It's recommended that you practice with two colors first to get the desired effect. Apply the dark color stain first and dry brush. After it is completely dry, apply the second stain color, lighter shade. Make sure the darker color is visible through the lighter shade of stain. Dry brush the second coat to get to the look desired.

